

ADP Bench



Product Sheet — 2025

+Halle[®]

Introducing the ADP Bench (Adults Don't Play), an interactive element designed for public spaces, that conveys a non-verbal message and invites you to take ownership. It even allows you to decide on its very function. The ADP Bench is designed by Copenhagen-based studio Spacon, made in collaboration with +Halle® in response to the sixth Annual Briefing based on the theme of 'Playing'.

Designed by SPACON

Spacon & X is an award-winning, cross-disciplinary design and architecture studio that prioritizes exploration. Based in Copenhagen and established in 2014, our intention is to craft unexpected pieces, spaces and experiences to present a world full of unimaginable possibilities.

Our work varies in scale, ranging from furniture products to interior design to larger building projects. Whenever we create, the intention is to be honest and fearless in our approach -- working closely with clients, suppliers and collaborators to present a personalised final result, underpinned by a synthesis between our intuitive design practice and the client's brand identity.



Adjustable seating



Inspiration:

Triggered by symmetry

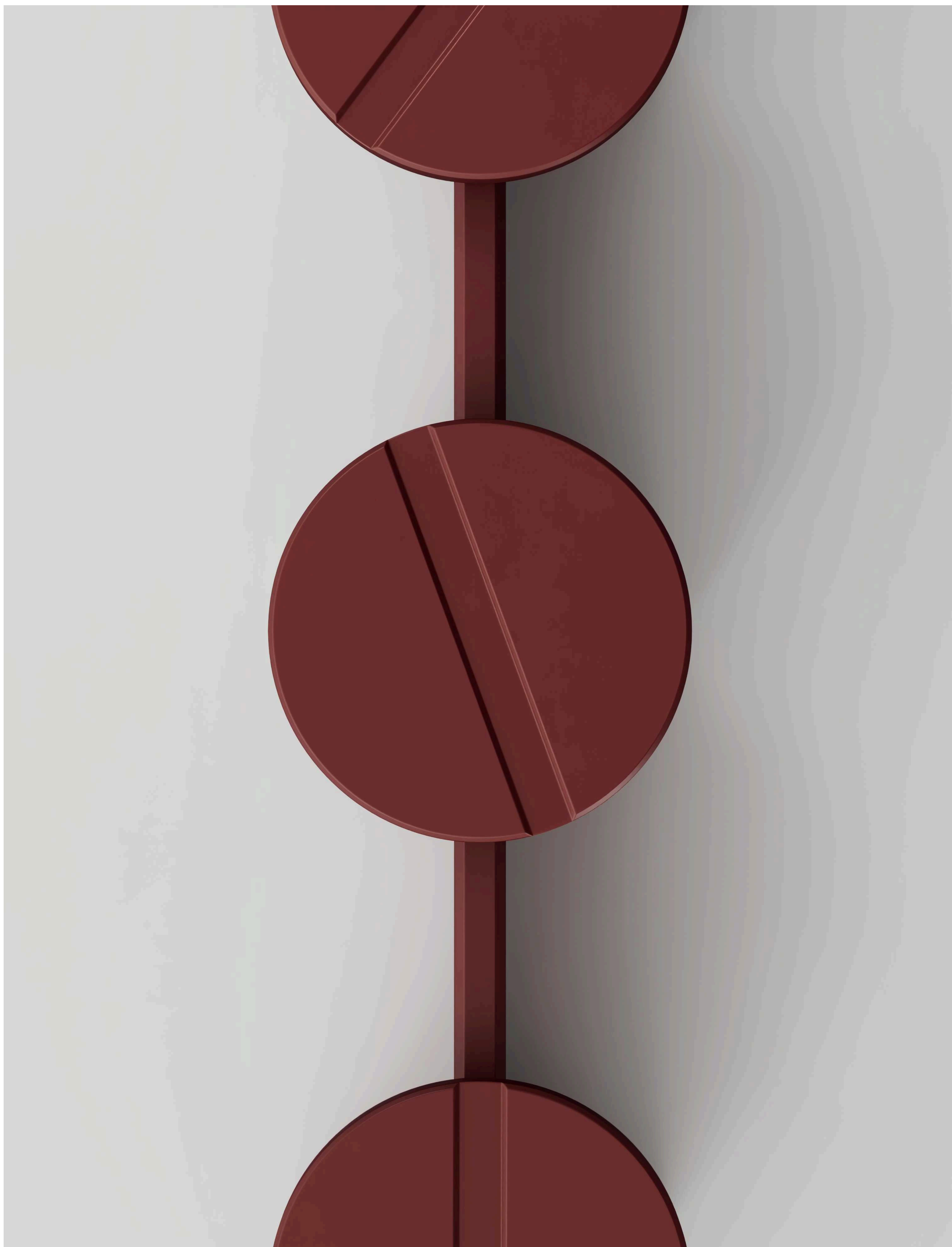

Specifications

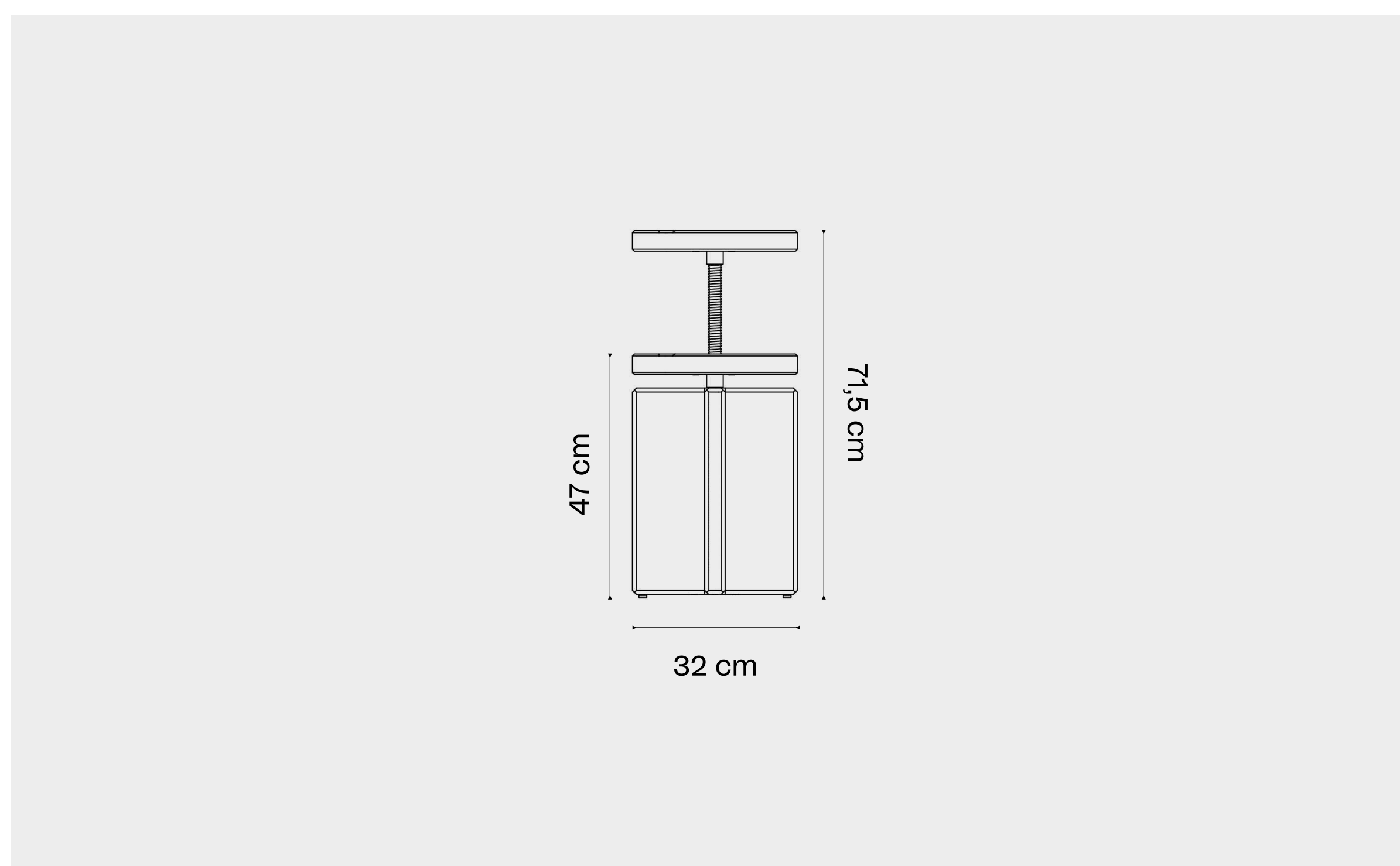
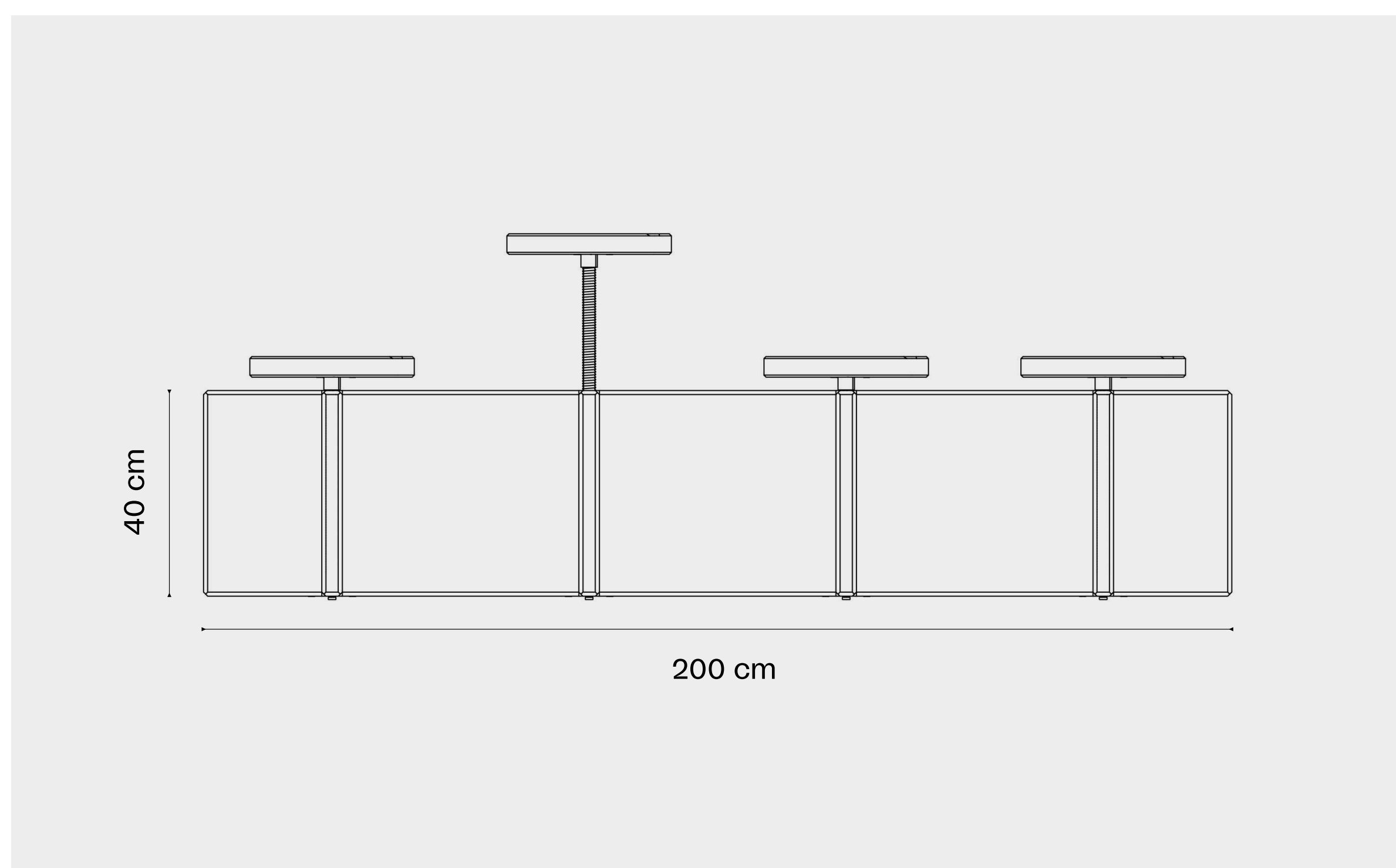

Materials & dimensions:

W200 x D32

Seat height: 47 cm — 71,5 cm

Weight: 48,3 kg

Powder coated MDF (Gloss 6—10)

Spindle: Polished chrome

Plastic gliders

Assembly:

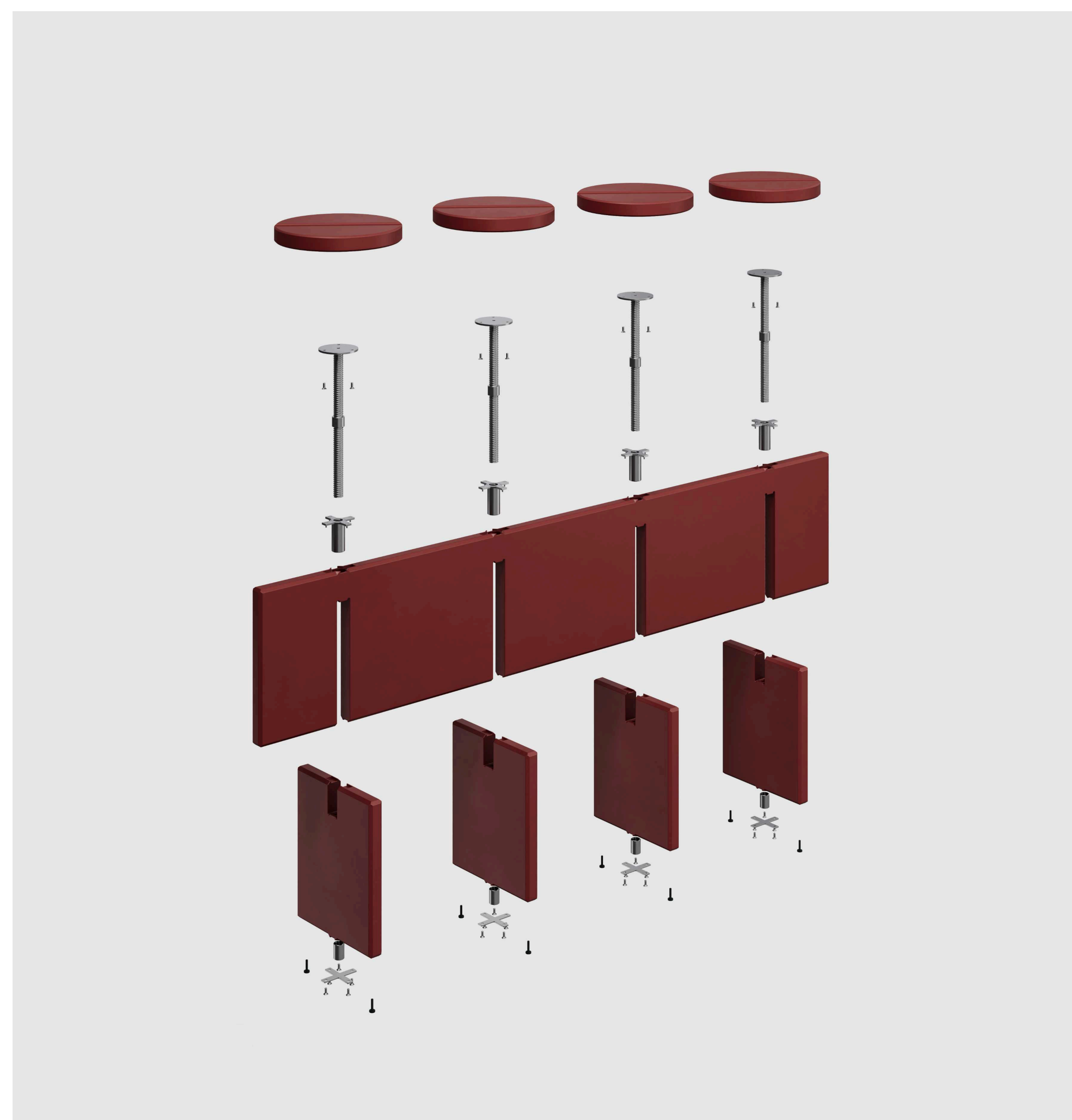

Colours



● Plum



● Ivory



● Steel Blue



● Pale Lime

Interview

Triggered by symmetry

Introducing the ADP Bench (Adults Don't Play), an interactive element designed for public spaces, that conveys a non-verbal message and invites you to take ownership. It even allows you to decide on its very function. This wooden bench is designed by Copenhagen-based studio Spacon, made in collaboration with +Halle® in response to the fifth Annual Briefing based on the theme of 'Playing'.

Inspired by behavioural research shared by the University of Southern Denmark on the briefing day, Spacon explored human triggers in a subtle but most humanistic way. The result: a bench that makes you engage, like an adult.

"The Annual Briefing on Playing had a fantastic energy; it was clear from the beginning that the group wanted to avoid gimmicks and stay close to reality. I think the ADP Bench beautifully tells that story, being true to intuitive behaviours we find in public spaces today," Martin Halle, CEO of +Halle®, says.

"We had the chance to study playing from a social scientific standpoint, immerse ourselves in the mental triggers that surround the theme and share those in critical discussions with our peers. Having the feedback from the other skilled designers (Philippe Malouin and Raw-Edges) was a designer-to-designer dialogue we had longed for," Svend Jacob Pedersen, Founding Partner, Spacon, reflects.



Svend Jacob Pedersen

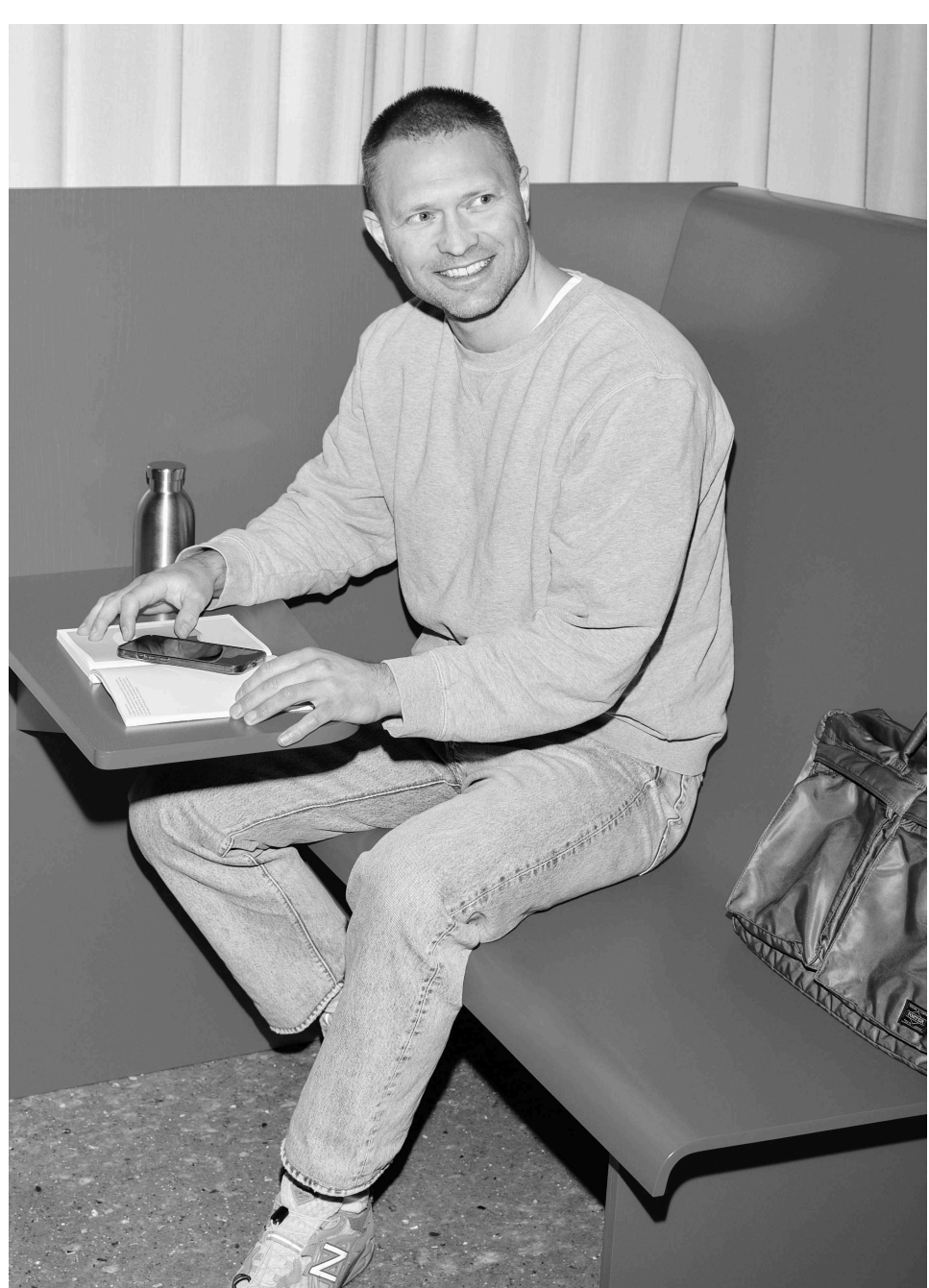

Martin Halle

Subtle play

The starting point for the ADP bench is interaction and, ultimately, personal ownership of a piece of furniture in the public realm. But interestingly, the research began elsewhere. In the urge or compulsion to find symmetry or align objects that are chaotic or misaligned, we hear Pedersen:

"We struggled with the theme at first. Asking ourselves, how do you contribute with something valuable in this category? To answer this question, we examined the engaging characteristics of symmetry," says Pedersen, and continues, "We looked at toys, particularly a box of Lego, and the attraction to organise the chaos and take personal ownership of the order created. That's the fundament. A businessman in a public space playing with a bench seat is built on that same theory. Proving that interaction with the world empowers."

Align the groove

Across the ADP Bench is a graphic element that speaks volumes without ever shouting. A quiet, but distinct graphic, speaking to the instinctual behaviour of wanting to adjust the seats to form a straight line.

"When looking at popular culture, internet memes, or viral connotations of symmetry compulsions, we found a picture of a sewer cover with a street line painted across it; the lock just turned a little to create a misalignment. This image communicates directly to the human temptation to want to turn the cover to make it right. And that image was something we ended up translating to a multifunctional bench, in a very direct way," Pedersen explains.

Hybrid use

The wooden ADP Bench can be seen as an interactive mental trigger and a hybrid set of seats and tables. Mimicking a classic piano stool with a swivel, the ADP Bench can be adjusted to serve as a set of low, standard, or high seats mixed with table height options. Included are, of course, all the measures in between, with endless combinations.

"Every function has a purpose in the ADP bench; at first you might want to sit down alone with a laptop and a coffee, then you might need people sitting next to you, which means you wire all the seats back down and shapeshift the bench," says Pedersen.

Graphic language

The ADP Bench is a conversation starter, especially with the transformative characteristics of the bench. You may even need to negotiate with the person next to you on how you want to sit.

"The playful tension of the ADP bench brilliantly captures the behaviour around taking ownership of public space. That the ADP bench successfully speaks to the public using a distinct language is a testament to Spacon & X's ability to establish a contract with the user of the furniture they create. At +Halle®, this captures the fundament of being shaped by behaviour," Halle reflects.

"In today's public realm, communication is vital, but it requires that the furniture that has something to say," Pedersen concludes.







+Halle A/S
Europa Plads 16, 3rd DK-8000 Aarhus C
+45 70 26 66 04
info@plushalle.dk

Explore the whole collection: www.plushalle.com

+Halle[®]