

# CUBICLE Work Station



Product sheet — 27062023

**+Halle<sup>®</sup>**

With their distinctively minimalist Cubicle collection, Stockholm-based design studio Form Us With Love is showing us how a simple bench and wall system can create an elegantly defined space that improves mental focus.

Built-in response to +Halle's lively and collaborative Annual Briefing discussions on Producing, Cubicle comprises a conceptually fresh take on a traditional cubicle — including a meter-twenty wall, a one-and-a-half seater bench and a comfortable table. The innovative 'quarter' structure is indicative of how far public seating has come, catering as it now does to our need for spaces that encourage focus as much as interaction.

---

CUBICLE Work Station

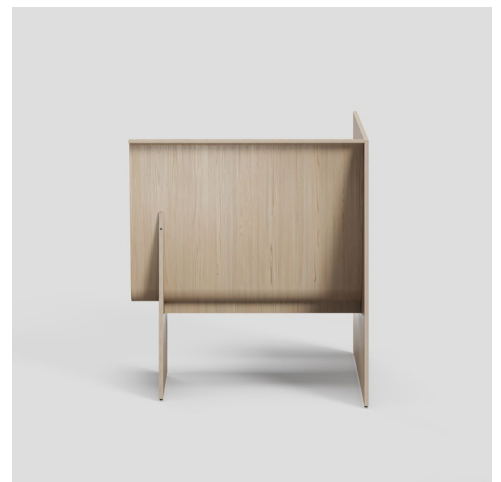

# Specifications

MODEL:	LENGTH:	WIDTH:	HEIGHT:	SEAT HEIGHT:	TABLE HEIGHT:
CUBICLE Work Station	107 cm	107 cm	119 cm	46 cm	73,5 cm

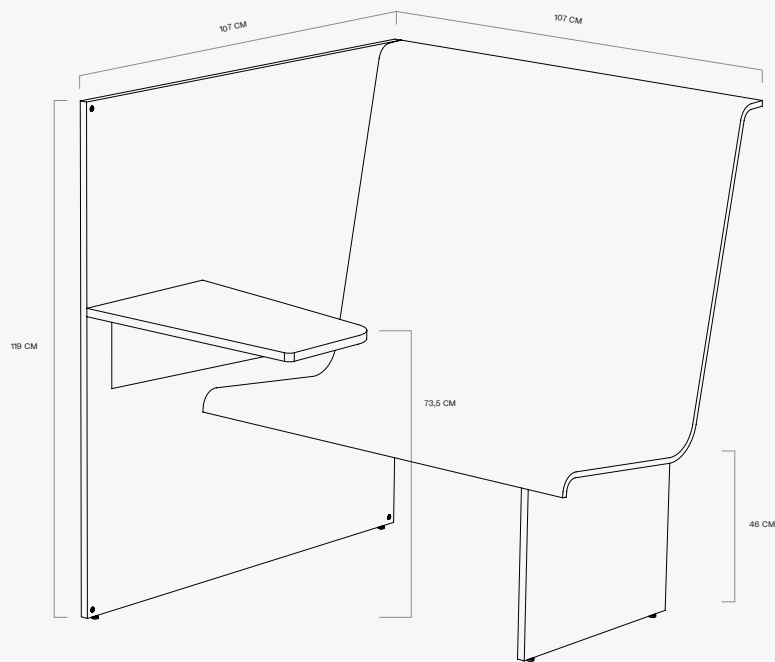

## Materials

Oak veneer / Plywood / Optional upholstery / Adjustable gliders

## Designed by Form Us With Love

While renowned for an explorative process, this Swedish studio delivers minimal and improved solutions for everyday objects. Continuously referred to as responsible and critical, the studio's mission is to create design applications based on a circular economy.

The studio is famous for challenging typologies of the public realm, positioned between human behaviour and industrial sustainability. This is precisely why; +Halle's Annual Briefs on Dwelling, Sharing and Producing were given to the studio.

# Configurations



# Details

## Optional upholstery



## Optional power integration



# Coloured version



# Interview

## *Alone with the world*

Getting things done in public environments often calls for a hideout, a place where you get comfortable enough so you can relax and let your mind flow for hours at a time.

Cubicle is a spatial installation from Form Us With Love that redefines what it means to create a space for concentration and productivity. To enter a Cubicle is to find yourself in a familiar frame – not so different from a compartment seat on a train – somewhere you are alone with your thoughts for a time, while still feeling connected to the wider environment.

## *What is your favourite seat?*

“During the Annual Briefing on producing, we had long discussions of emerging behaviours in spatial comfort. For instance, we had architectural PhD candidate Andrew Khoudi compare data of preferred seats in the Dokk1 library, in Aarhus, and learnt that the seat with the back to the wall, facing outwards, was the most popular among visitors. It is by looking at this kind of insight, that we can continue to debate the impact of architectural installations, and hopefully enhance them through interventions like Cubicle,” says Martin Halle, creative director at +Halle.

## *Hive mind*

“These half-rooms are a homage to the cubicle,” says John Löfgren, creative director at Form Us With Love. “At first, we looked back: everyone had their own room, imagine just like in Jacques Tati’s film *Playtime* (1967), but as we began to plan the space for today, the flexibility needed meant we were left with a series of multiple bench-table-wall structures, still delivering on that idea of defining ‘my own space’ but living openly in a network, where pieces appear together through multiple constellations.”

## *Direction of travel*

The unexpected combination of a tall wooden bench and a single wooden wall inspires users and specifiers to be creative. Cubicle is designed both as an open and a mirrored version, this to be effortlessly configured in groups.

“You can have twenty of them in a space if you like, or just one. Cubicle functions similarly to any transport system, where you are sitting alongside each other or front facing or simply on your own,” Gabriel Follonier, Industrial designer at Form Us With Love, explains.

## *The architecture of flow*

Inspired by Swedish Architect Gunnar Asplund’s fixed wooden benches built for the Woodland Chapel in 1935, Form Us With Love has created a fresh, elegant yet still utilitarian, almost brutalist take on a tall bench. With bent plywood and a sturdy wall forming the legs, the formal language is very much an architectural one.

The design studio hopes that the Cubicle collection can be used in a variety of settings, itself inviting a wider public conversation about how we focus.

## *Journey mode*

“We wanted to give people a sense of mental relief,” says Follonier. “Recalling our joint love for train travel, being tucked into bent seats and effective table sizing. When we were testing the prototypes of Cubicle in the studio, we all spent time seated in the corner. With similarly generous properties, yet small means, the experience connected us emotionally to the headspace of a journey.”

## *Cubicle state of mind*

Cubicle is a practical architectural structure, designed to meet emergent behaviours around modern flexible spaces. With a minimal silhouette and a generous design that meets real human needs — there is an intriguing dialogue at play. Fresh, yet familiar, Cubicle pulls people in, to find that moment of solitude in the middle of it all.

“It is perhaps the energy in the collection that I see as the biggest potential, it’s a utilitarian sculpture for your productive thoughts, that can be scaled up to serve an entire company, get ready for some big ideas!” Halle concludes.

—→ Learn more about the CUBICLE Work Station and download assets  
<https://plushalle.com/>



+Halle A/S  
Europa Plads 16, 3rd DK-8000 Aarhus C  
+45 70 26 66 04  
[info@plushalle.dk](mailto:info@plushalle.dk)

[www.plushalle.com](http://www.plushalle.com)

**+Halle<sup>®</sup>**